

# A-W & A-F Oil Separators

The A-W and A-F are used for multiple compressor racks in supermarkets and air conditioning systems for use with HCFCs, HFCs and their lubricants.

## Features

- Hermetic welded or accessible bolted flange construction
- Solid copper connections
- Corrosion resistant epoxy powder paint



## Nomenclature example: AW 5582 4

<b>A</b>	<b>W</b>	<b>5582</b>	<b>4</b>
Series	W = Welded F = Flanged	Model Number	Connection Size (in 1/8")

## Specifications

- Maximum working pressure: 450 psi
- UL/CUL file number: SA10468

## Ordering Information\* and Capacity Table

Description				R-12				R-22/R-407C				R-502				R-134a				R-404A/R-507			
FLANGED	PCN	SEALED	PCN	-40 F/C		40F (4C)		-40F/C		40F (4C)		-40F/C		40F (4C)		-40F/C		40F (4C)		-40F/C		40F (4C)	
				Tons	kW	Tons	kW	Tons	kW	Tons	kW	Tons	kW	Tons	kW	Tons	kW	Tons	kW	Tons	kW	Tons	kW
A-F 58824	060877	A-W 55824	060933	1	3.5	1.5	5.3	1.5	5.3	2	7.1	1.5	5.3	2	7.08	1	3.5	1.8	6.2	1.5	5.3	2	7.0
A-F 58855	060878	A-W 55855	060934	3	10.6	4	14.2	4.5	15.9	5.5	19.5	4.8	16.8	5.8	20.4	3.3	11.5	4.5	15.9	4	14.2	5.5	19.0
A-F 58877	060879	A-W 55877	060931	4.5	15.9	5.5	19.5	7	24.8	8	28.3	7.5	26.6	8.5	30.1	4.8	16.8	6.5	23	6.5	23	8.5	30.0
A-F 58889	060759	A-W 55889	060974	6	21.2	7.5	26.6	9	31.9	11	37.2	9.5	33.6	11.5	40.7	6.5	23	8.5	30.1	8.5	30.1	11	38.0
A-F 589011	060760	A-W 559011	060930	7.5	26.6	10	35.4	11.5	40.7	14	47.8	12	42.5	14.5	51.3	8	28.3	11.5	40.7	10.5	37.2	14	49.0
A-F 589213	060761	A-W 559213	060975	9	31.9	11.5	40.7	14	49.6	18	62	16	56.6	17.5	62	9.5	33.6	13.3	46.9	14	49.6	17	60.0
-	-	A-W 569011	060978	9	31.7	12	42.3	13	45.8	14	49.8	15	52.8	20	70.4	9.5	33.4	13.7	48.2	11	38.7	19	66.9
A-F 579213	060875	A-W 569213	060979	11	38.9	14	49.6	16	56.6	18	63.7	20	70.8	24	85	11.8	41.6	16	56.6	17.5	62	23	81
A-F 579417	060876	A-W 569417	060980	17	60.2	22	77.9	25	88.5	30	106	30	106	35	124	18	63.7	25.6	89.4	26	92.	34	121

\*See replacement parts page. Repair kits for style 2 only.

## Dimensional Data

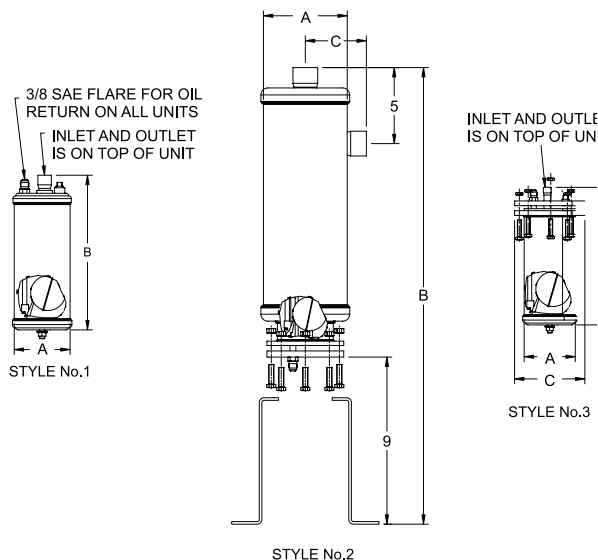

## Seal Units: A-W

Description	Style No.	Connection Size	Dimensions (in)		Replaceable Float PCN	Discharge Maximum CFM	Oil Pre-charge Amount (oz)
			A	B			
A-W 55824	1	1/2 ODF	4.0	10.75	N/A	1.49	17
A-W 55855		5/8 ODF		13.2		3.42	
A-W 55877		7/8 ODF		15.0		6.05	
A-W 55889		1-1/8 ODF		16.25		8.28	
A-W 559011		1-3/8 ODF		19.5		9.99	
A-W 559213		1-5/8 ODF		19.88		10.66	
A-W 569011		1-3/8 ODF		15.75		12.27	
A-W 569213	6.0	1-5/8 ODF	19.0	14.51	N/A	20	
A-W 569417		2-1/8 ODF	19.5	21.29			

## Flanged Units: A-F

Description	Style No.	Connection Size	Dimensions (in)			Replaceable Float PCN	Discharge Maximum CFM	Oil Pre-charge Amount (oz)
			A	B	C			
A-F 58824	3	1/2 ODF	4.0	10.5	5.5	N/A	1.49	17
A-F 58855		5/8 ODF		15.0			3.42	
A-F 58877		7/8 ODF		18.0			6.05	
A-F 58889		1 1/8 ODF		21.25			8.28	
A-F 589011		1 3/8 ODF		21.37			9.99	
A-F 589213		1 5/8 ODF		21.75			10.66	
A-F 579213	2	1 5/8 ODF	6.0	20.12	4.37	065847	23.93	20
A-F 579417		2 1/8 ODF	20.31	4.63	30.93			