

Data sheet

Thermostatic expansion valves

Type T2 / TE2



Thermostatic expansion valves regulate the injection of refrigerant liquid into evaporators.

Injection is controlled by the refrigerant superheat.

Therefore the valves are especially suitable for liquid injection in "dry" evaporators where the superheat at the evaporator outlet is proportional to the evaporator load.

Features

- *Large temperature range*
Equally applicable to freezing, refrigeration and air conditioning applications.
- *Interchangeable orifice assembly*
 - easy storage
 - easy capacity matching
 - better service.
- *Rated capacities from 0.96 to 20.5 kW (0.27 to 5.82 TR) for R407C.*
- *Can be supplied with MOP (Max. Operating Pressure)*
Protects the compressor motor against excessive evaporating pressure during normal operation.
- *Stainless steel bulb and Danfoss patented bulb strap*
Fast and easy to install.
Good temperature transfer from pipe to bulb.
- *Valves for special temperature ranges can be supplied.*
- Design protected

Identification

The thermostatic element has laser engraved data on top of the diaphragm. This engraving gives valve type (with code number), evaporating temperature range, MOP point, refrigerant, and max. working pressure. PS/MWP.

The code refers to the refrigerant for which the valve is designed:

- X = R22/R407C¹⁾
- Z = R407C
- N = R134a
- S = R404A/ R507

Production place and date
N4511A =

- N = Nordborg, Denmark
- (BE = Wuqing, China)
- 45 = week
- 11 = 2011
- A = Monday

¹⁾ For R407C plants, please select valves from the dedicated R407C program

Orifice assembly for T 2 and TE 2

The orifice assembly is marked with the orifice size (e.g. 06) and week stamp + last number in the year (e.g. 174).
The orifice assembly number is also given on the lid of its plastic container.

Capillary tube label for T 2 and TE 2

The label gives the orifice size (04) and consists of the lid of the orifice assembly plastic container. It can easily be fastened around the expansion valve capillary tube to clearly identify the valve size.

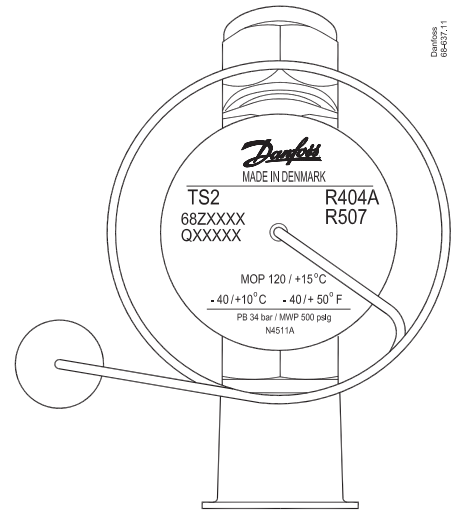

Danfoss 68-501.11

Orifice assembly and filter for flare x flare version for T 2 and TE 2

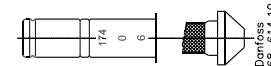

Danfoss 68-614.10

Capillary tube label T 2 and TE 2



Danfoss 68-501.11

Technical data

Max. temperature
Bulb, when valve is installed: 100 °C
Bulb, element not mounted: 60 °C

Max. test pressure
PT = 38 bar

Min. temperature
T 2 – TE 2: –60 °C

Max. working pressure
PS/MWP = 34 bar

MOP-points

Refrigerant	Range N	Range NM	Range NL	Range B
	–40 °C – +10 °C	–40 °C – –5 °C	–40 °C – –15 °C	–60 °C – –25 °C
MOP-point in evaporating temperature t_e and evaporating pressure p_e ¹⁾				
	+15 °C / +60 °F	0 °C / +32 °F	–10 °C / +15 °F	–20 °C / –4 °F
R22	100 psig/6.9 bar (abs)	60 psig/4.0 bar (abs)	35 psig/2.4 bar (abs)	20 psig/1.4 bar (abs)
R407C	95 psig/6.6 bar (abs)			
R134a	55 psig/3.8 bar (abs)	30 psig/2.0 bar (abs)	15 psig/1.0 bar (abs)	
R404A/R507	120 psig/8.3 bar (abs)	75 psig/5.2 bar (abs)	50 psig/3.4 bar (abs)	30 psig/2.1 bar (abs)

¹⁾ Pe in bar gauge

Superheat

- SS = static superheat
- OS = opening superheat
- SH = SS + OS = total superheat
- Q_{nom} = rated capacity
- Q_{max} = maximum capacity

The standard superheat setting SS is 5 K for valves without MOP and 4 K for valves with MOP.
The opening superheat OS is 6 K from when opening begins to where the valve gives its rated capacity Q_{nom} .

Static superheat SS can be adjusted with setting spindle.

Example
Static superheat SS = 5 K
Opening superheat OS = 6 K
Total superheat SH = 5 + 6 = 11 K

**Design
Function**

General

T 2 and TE 2 valves have an interchangeable orifice assembly.

The orifice assembly is suitable for all versions of valve body and refrigerants and in all evaporating temperature ranges.

The charge in the thermostatic element depends on the refrigerant and evaporating temperature range.

The valves are available with internal (T2) or external (TE2) pressure equalization.

External pressure equalization should always be used on systems with liquid distributors.

The bulb gives fast and precise reaction to temperature changes in the evaporator. The bulb is fixed with a Danfoss patented bulb strap for quick, easy and reliable connection. The valves are able to withstand the effects that normally occur with hot gas defrosting.

To ensure long operating life, the valve cone and seat are made of a special alloy with particularly good wear qualities.

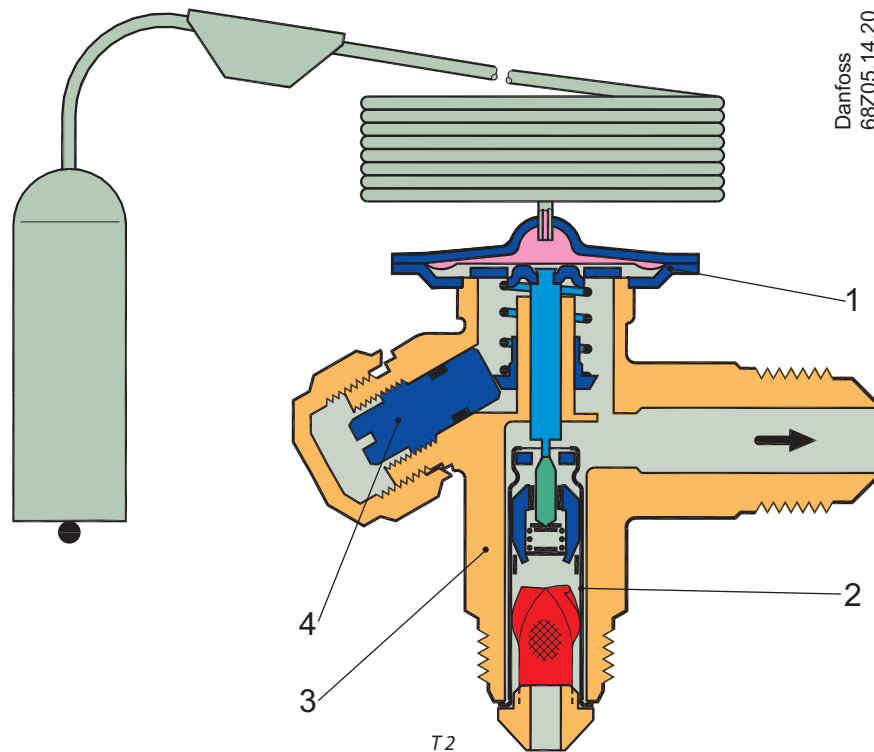

- 1. Thermostatic element (diaphragm)
- 2. Interchangeable orifice assembly
- 3. Valve body
- 4. Superheat setting spindle (see instructions)

Technical data and ordering

T2/TE2 Thermostatic element with bulb strap
Flare x flare

Capillary tube: 1.5 m
Range N = -40 – +10 °C
Range B = -60 – -25 °C
Range NM = -40 – -5 °C MOP 0 °C
Range NL = -40 – -15 °C MOP -10 °C

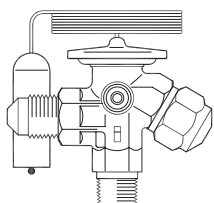
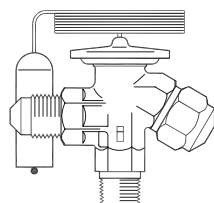

Refrigerant	Type	Range	MOP	Pressure equalization Flare	Connection flare inlet x outlet		Code no. Multi pack
					[in.]	[mm]	
R22/R407C ¹⁾	TX 2	-40 – +10 °C	–	–	3/8 x 1/2	10x12	068Z3206
	TX 2	-40 – +10 °C	+15 °C	–	3/8 x 1/2	10x12	068Z3208
	TX 2	-40 – -5 °C	0 °C	–	3/8 x 1/2	10x12	068Z3224
	TX 2	-40 – -15 °C	-10 °C	–	3/8 x 1/2	10x12	068Z3226
	TX 2	-60 – -25 °C	–	–	3/8 x 1/2	10x12	068Z3207
	TX 2	-60 – -25 °C	-20 °C	–	3/8 x 1/2	10x12	068Z3228
	TEX 2	-40 – +10 °C	–	1/4 in.	3/8 x 1/2	10x12	068Z3209
	TEX 2	-40 – +10 °C	+15 °C	1/4 in.	3/8 x 1/2	10x12	068Z3211
	TEX 2	-40 – -5 °C	0 °C	1/4 in.	3/8 x 1/2	10x12	068Z3225
	TEX 2	-40 – -15 °C	-10 °C	1/4 in.	3/8 x 1/2	10x12	068Z3227
	TEX 2	-60 – -25 °C	–	1/4 in.	3/8 x 1/2	10x12	068Z3210
R407C	TZ 2	-40 – +10 °C	–	–	3/8 x 1/2	10x12	068Z3496
	TZ 2	-40 – +10 °C	+15 °C	–	3/8 x 1/2	10x12	068Z3516
	TEZ 2	-40 – +10 °C	–	1/4 in.	3/8 x 1/2	10x12	068Z3501
	TEZ 2	-40 – +10 °C	+15 °C	1/4 in.	3/8 x 1/2	10x12	068Z3517
R134a	TN 2	-40 – +10 °C	–	–	3/8 x 1/2	10x12	068Z3346
	TN 2	-40 – +10 °C	+15 °C	–	3/8 x 1/2	10x12	068Z3347
	TN 2	-40 – -5 °C	0 °C	–	3/8 x 1/2	10x12	068Z3393
	TN 2	-40 – -15 °C	-10 °C	–	3/8 x 1/2	10x12	068Z3369
	TEN 2	-40 – +10 °C	–	1/4 in.	3/8 x 1/2	10x12	068Z3348
	TEN 2	-40 – +10 °C	+15 °C	1/4 in.	3/8 x 1/2	10x12	068Z3349
	TEN 2	-40 – -5 °C	0 °C	1/4 in.	3/8 x 1/2	10x12	068Z3392
	TEN 2	-40 – -15 °C	-10 °C	1/4 in.	3/8 x 1/2	10x12	068Z3370
R404A/R507	TS 2	-40 – +10 °C	–	–	3/8 x 1/2	10x12	068Z3400
	TS 2	-40 – +10 °C	+15 °C	–	3/8 x 1/2	10x12	068Z3402
	TS 2	-40 – -5 °C	0 °C	–	3/8 x 1/2	10x12	068Z3406
	TS 2	-40 – -15 °C	-10 °C	–	3/8 x 1/2	10x12	068Z3408
	TS 2	-60 – -25 °C	–	–	3/8 x 1/2	10x12	068Z3401
	TS 2	-60 – -25 °C	-20 °C	–	3/8 x 1/2	10x12	068Z3410
	TES 2	-40 – +10 °C	–	1/4 in.	3/8 x 1/2	10x12	068Z3403
	TES 2	-40 – +10 °C	+15 °C	1/4 in.	3/8 x 1/2	10x12	068Z3405
	TES 2	-40 – -5 °C	0 °C	1/4 in.	3/8 x 1/2	10x12	068Z3407
	TES 2	-40 – -15 °C	-10 °C	1/4 in.	3/8 x 1/2	10x12	068Z3409
	TES 2	-60 – -25 °C	–	1/4 in.	3/8 x 1/2	10x12	068Z3404
TES 2	-60 – -25 °C	-20 °C	1/4 in.	3/8 x 1/2	10x12	068Z3411	
R407F/R407A	T2	-40 – +10 °C	–	–	3/8 x 1/2	10x12	068Z3715
	TE2	-40 – +10 °C	–	1/4 in.	3/8 x 1/2	10x12	068Z3714

¹⁾ For R407C plants. Please select valves from the dedicated R407C program

Technical data and ordering

T2/TE2 Thermostatic element with bulb strap
Flare x solder

Capillary tube: 1.5 m
Range N = -40 – +10 °C
Range NL = -40 – -15 °C
Range B = -60 – -25 °C

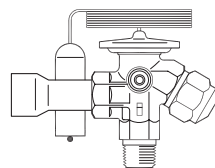
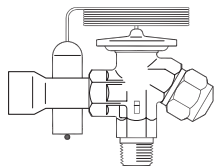

Refrigerant	Type	Range	MOP	Pressure equalization solder	Connection		Code no. Multi pack
					inlet (Flare) x outlet (Solder)		
					[in.]	[mm]	
R22/R407C ¹⁾	TX 2	-40 – +10 °C	–	–	3/8 x 1/2	–	068Z3281
	TX 2	-40 – +10 °C	–	–	–	10x12	068Z3302
	TX 2	-40 – +10 °C	+15 °C	–	3/8 x 1/2	–	068Z3287
	TX 2	-40 – +10 °C	+15 °C	–	–	10x12	068Z3308
	TX 2	-40 – -15 °C	-10 °C	–	–	10x12	068Z3366
	TX 2	-60 – -25 °C	–	–	3/8 x 1/2	–	068Z3357
	TX 2	-60 – -25 °C	–	–	–	10x12	068Z3361
	TX 2	-60 – -25 °C	-20 °C	–	3/8 x 1/2	–	068Z3319
	TEX 2	-40 – +10 °C	–	1/4 in.	3/8 x 1/2	–	068Z3284
	TEX 2	-40 – +10 °C	–	6 mm	–	10x12	068Z3305
	TEX 2	-40 – +10 °C	+15 °C	1/4 in.	3/8 x 1/2	–	068Z3290
	TEX 2	-40 – +10 °C	+15 °C	6 mm	–	10x12	068Z3311
	TEX 2	-40 – -15 °C	-10 °C	6 mm	–	10x12	068Z3367
	TEX 2	-60 – -25 °C	–	1/4 in.	3/8 x 1/2	–	068Z3359
	TEX 2	-60 – -25 °C	–	6 mm	–	10x12	068Z3363
TEX 2	-60 – -25 °C	-20 °C	–	3/8 x 1/2	–	068Z3320	
R407C	TZ 2	-40 – +10 °C	–	–	–	10x12	068Z3502
	TZ 2	-40 – +10 °C	+15 °C	–	3/8 x 1/2	–	068Z3329
	TZ 2	-40 – +10 °C	+15 °C	–	–	10x12	068Z3514
	TEZ 2	-40 – +10 °C	–	1/4 in.	3/8 x 1/2	1/2 in.	068Z3446
	TEZ 2	-40 – +10 °C	–	6 mm	–	10x12	068Z3503
	TEZ 2	-40 – +10 °C	+15 °C	1/4 in.	3/8 x 1/2	–	068Z3447
	TEZ 2	-40 – +10 °C	+15 °C	6 mm	–	10x12	068Z3515
R134a	TN 2	-40 – +10 °C	–	–	3/8 x 1/2	–	068Z3383
	TN 2	-40 – +10 °C	–	–	–	10x12	068Z3384
	TN 2	-40 – +10 °C	+15 °C	–	3/8 x 1/2	–	068Z3387
	TN 2	-40 – +10 °C	+15 °C	–	–	10x12	068Z3388
	TEN 2	-40 – +10 °C	–	1/4 in.	3/8 x 1/2	–	068Z3385
	TEN 2	-40 – +10 °C	–	6 mm	–	10x12	068Z3386
	TEN 2	-40 – +10 °C	+15 °C	1/4 in.	3/8 x 1/2	–	068Z3389
TEN 2	-40 – +10 °C	+15 °C	6 mm	–	10x12	068Z3390	
R404A/R507	TS 2	-40 – +10 °C	–	–	3/8 x 1/2	–	068Z3414
	TS 2	-40 – +10 °C	–	–	–	10x12	068Z3435
	TS 2	-40 – +10 °C	+15 °C	–	3/8 x 1/2	–	068Z3416
	TS 2	-40 – +10 °C	+15 °C	–	–	10x12	068Z3423
	TS 2	-40 – -15 °C	-10 °C	–	3/8 x 1/2	–	068Z3429
	TS 2	-40 – -15 °C	-10 °C	–	–	10x12	068Z3436
	TS 2	-60 – -25 °C	–	–	3/8 x 1/2	–	068Z3418
	TS 2	-60 – -25 °C	–	–	–	10x12	068Z3425
	TS 2	-60 – -25 °C	-20 °C	–	3/8 x 1/2	–	068Z3420
	TS 2	-60 – -25 °C	-20 °C	–	–	10x12	068Z3427
	TES 2	-40 – +10 °C	–	1/4 in.	3/8 x 1/2	–	068Z3415
	TES 2	-40 – +10 °C	–	6 mm	–	10x12	068Z3422
	TES 2	-40 – +10 °C	+15 °C	6 mm	–	10x12	068Z3424
	TES 2	-40 – +10 °C	+15 °C	1/4 in.	3/8 x 1/2	–	068Z3417
	TES 2	-40 – -15 °C	-10 °C	1/4 in.	3/8 x 1/2	–	068Z3430
	TES 2	-40 – -15 °C	-10 °C	6 mm	–	10x12	068Z3437
	TES 2	-60 – -25 °C	–	1/4 in.	3/8 x 1/2	–	068Z3419
	TES 2	-60 – -25 °C	–	6 mm	–	10x12	068Z3426
	TES 2	-60 – -25 °C	-20 °C	1/4 in.	3/8 x 1/2	–	068Z3421
TES 2	-60 – -25 °C	-20 °C	6 mm	–	10x12	068Z3428	
R407F/ R407A	T2	-40 – +10 °C	–	–	3/8 x 1/2	–	068Z3716
	TE2	-40 – +10 °C	–	1/4 in.	3/8 x 1/2	–	068Z3713

¹⁾ For R407C plants, please select valves from the dedicated R407C program

Flare connections

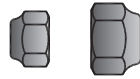

Connection for copper tubing with outside diameter		Reducer for copper tubing with outside diameter		Code no.
in.	mm	in.	mm	
1/4	6			011L1101
3/8	10			011L1135
1/2	12			011L1103
		1/4	6	011L1107

Example :

A TE 2 thermostatic expansion valve consists of two elements + flare nuts if required:

- 1 thermostatic element
- 1 orifice assembly and flare nuts

When ordering one thermostatic expansion valve, TEX 2 with orifice 01, five code numbers are required:

- 1-off thermostatic element **068Z3209**
- 1-off orifice assembly 01 **068-2010**
- 1-off 3/8 in. flare nut **011L1135**
- 1-off 1/2 in. flare nut **011L1103**
- 1-off 1/4 in. flare nut **011L1101**

Range N: -40 to +10 °C

Orifice no.	Nominal capacity in tons (TR)						Nominal capacity in kW					
	R22	R407C	R134a	R404A R507	R407A	R407F	R22	R407C	R134a	R404A R507	R407A	R407F
0X	0.25	0.27	0.19	0.18	0.25	0.28	0.90	0.96	0.68	0.65	0.88	1.0
00	0.51	0.53	0.34	0.37	0.49	0.56	1.8	1.9	1.2	1.3	1.7	2.0
01	0.99	1.0	0.59	0.75	1.0	1.1	3.5	3.7	2.1	2.6	3.4	3.9
02	1.3	1.4	0.73	1.1	1.3	1.5	4.7	5.0	2.6	3.7	4.7	5.4
03	2.3	2.4	1.2	1.8	2.3	2.6	8.0	8.5	4.3	6.3	8.0	9.2
04	3.5	3.7	1.8	2.8	3.5	4.1	12.2	12.9	6.4	10.0	12.4	14.3
05	4.8	4.9	2.4	3.7	4.6	5.4	16.8	17.1	8.4	13.1	16.3	19.0
06	5.6	5.8	2.9	4.4	5.6	6.5	19.7	20.5	10.1	15.6	19.6	22.9

The rated capacity is based on:
 Evaporating temperature $t_e = +4.4\text{ °C}$
 Condensing temperature $t_c = +38\text{ °C}$
 Refrigerant temperature ahead of valve $t_1 = +37\text{ °C}$

Orifice assembly with filter



Orifice no.	Code no.
0X	068-2002
00	068-2003
01	068-2010
02	068-2015
03	068-2006
04	068-2007
05	068-2008
06	068-2009

Orifice assembly with filter for solder adaptor



Orifice no.	Code no.
0X	068-2089
00	068-2090
01	068-2091
02	068-2092
03	068-2093
04	068-2094
05	068-2095
06	068-2096

Filter



Filter type	Code no. Multi pack
For flare connection	068-0003
For solder adaptor	068-0015

The adaptor is for use with thermostatic expansion valves T2 and TE2. When the adaptor is fitted correctly it meets the sealing requirements of DIN 8964. The flare orifice in T2 and TE2 can be used with a solder adaptor when the orifice filter is replaced with a specific filter intended for solder adaptors.

Only in this way the sealing requirements of DIN 8964 can be fulfilled. Solder adaptors for filter driers (FSA) must not be used on the T2 inlet.

Solder adaptor



The adaptor is for use with thermostatic expansion valves T 2 and TE 2 with flare x solder connections. When the adaptor is fitted correctly it meets the sealing requirements of DIN 8964.

The adaptor offers the following advantages:

- The orifice assembly can be replaced.
- The filter can be cleaned or replaced.

When using the solder adapter, a special orifice assembly is required. Please use the following tables to select both the appropriate adapter and orifice assembly.

Only in this way can the sealing requirements of DIN 8964 be fulfilled.

Solder adaptor for filter drier (FSA) may not be used in the T 2 inlet.

Solder adaptor without orifice assembly and filter

Connection ODF solder	Code no.
1/4 in.	068-2062
6 mm	068-2063
3/8 in.	068-2060
10 mm	068-2061

Filter for solder adaptor

Description	Code no.
Filter excl. orifice assembly	068-0015

Bulb strap (Danfoss patented)

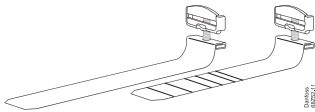

Each valve is delivered with a Danfoss patented bulb strap. Spares can be ordered.

Description	Pack mode	Quantity / pack	Code no.
Bulb strap 0.4 mm Max. 28 mm tube	I	45	068U3505
Bulb strap 0.4 mm Max. 50 mm tube	I	45	068U3506
Bulb strap 0.4 mm Max. 28 mm tube	M	25	068U3507
Bulb strap 0.4 mm Max. 50 mm tube	M	25	068U3508

How to select a valve

Example:

Refrigerant = R407C
 Q (capacity) = 1.1kW
 T_{cond} (condensing temperature) = 25 °C
 T_{evap} (evaporator temperature) = -30 °C
 T_{sub} (subcooling temperature) = 10 K
 D_{pd} (distributer pressure drop) = 1 bar

Q (capacity) = 1.1kW
 f_{sub} (subcooling correction factor) = 1.07
 f_p (distribution correction factor) = 0.96

$$\frac{Q}{f_{sub} \times f_p} = \text{Selected capacity}$$

$$\frac{1.1}{1.07 \times 0.96} = 1.1 \text{ kW}$$

The selection will be:
 TE2 orifice 00 (1.21 kW > 1.1 kW)

Capacity in kW, range N -40 °C to +10 °C. Opening superheat sh= 6 K

Valve type	Orifice no.	Cond. temp. [°C]	Evaporating [°C]			
			-40	-30	-20	-10
T2 / TE2	0X	25	0.76	0.83	0.88	0.90
T2 / TE2	00		0.99	1.21	1.42	1.60
T2 / TE2	01		1.41	1.80	2.27	2.77

Subcooling correction factor 'fsub'

Subcooling [K]	2	4	10	15
Correction factor	0.98	1.00	1.07	1.12

Distributer correction factor 'fp' *

Pressure drop [bar]	Evaporating temp. [°C]			
	-40	-35	-30	-25
0	1	1	1	1
"Pressure drop [bar]"	0.96	0.96	0.96	0.96
1.5	0.94	0.94	0.94	0.94
2	0.92	0.92	0.92	0.92

*calculated at 32 °C condensing temperature

Capacity

Capacity in kW, range N -40 °C to +10 °C. Opening superheat sh= 6 K

R22

Valve type	Orifice no.	Cond. temp. [°C]	Evaporating [°C]					
			-40	-30	-20	-10	0	10
			Capacity [kW]					
T2 / TE2	0X	25	0.75	0.82	0.86	0.86	0.81	0.68
T2 / TE2	00		0.95	1.18	1.39	1.53	1.55	1.37
T2 / TE2	01		1.32	1.72	2.18	2.63	2.91	2.78
T2 / TE2	02		1.49	1.98	2.57	3.24	3.82	3.88
T2 / TE2	03		2.49	3.32	4.32	5.43	6.40	6.57
T2 / TE2	04		3.59	4.79	6.35	8.16	9.72	9.88
T2 / TE2	05		4.69	6.25	8.30	10.80	13.10	13.50
T2 / TE2	06		5.53	7.36	9.73	12.70	15.40	16.00

Valve type	Orifice no.	Cond. temp. [°C]	Evaporating [°C]					
			-40	-30	-20	-10	0	10
			Capacity [kW]					
T2 / TE2	0X	35	0.78	0.86	0.91	0.93	0.92	0.85
T2 / TE2	00		0.99	1.23	1.47	1.67	1.77	1.72
T2 / TE2	01		1.37	1.80	2.31	2.86	3.33	3.50
T2 / TE2	02		1.56	2.08	2.74	3.54	4.38	4.92
T2 / TE2	03		2.62	3.51	4.62	5.96	7.39	8.35
T2 / TE2	04		3.85	5.12	6.83	8.98	11.20	12.70
T2 / TE2	05		5.03	6.68	8.93	11.90	15.30	17.50
T2 / TE2	06		5.89	7.82	10.40	13.90	17.90	20.70

Valve type	Orifice no.	Cond. temp. [°C]	Evaporating [°C]					
			-40	-30	-20	-10	0	10
			Capacity [kW]					
T2 / TE2	0X	45	0.80	0.88	0.94	0.97	0.98	0.95
T2 / TE2	00		1.01	1.26	1.52	1.75	1.90	1.94
T2 / TE2	01		1.41	1.85	2.39	3.00	3.59	3.96
T2 / TE2	02		1.61	2.14	2.84	3.72	4.74	5.60
T2 / TE2	03		2.71	3.64	4.82	6.32	8.08	9.63
T2 / TE2	04		4.06	5.37	7.14	9.47	12.20	14.50
T2 / TE2	05		5.30	7.01	9.37	12.60	16.70	20.30
T2 / TE2	06		6.19	8.18	10.90	14.70	19.50	24.00

Valve type	Orifice no.	Cond. temp. [°C]	Evaporating [°C]					
			-40	-30	-20	-10	0	10
			Capacity [kW]					
T2 / TE2	0X	55	0.79	0.88	0.94	0.98	1.00	0.99
T2 / TE2	00		1.01	1.26	1.53	1.77	1.95	2.04
T2 / TE2	01		1.42	1.87	2.42	3.06	3.71	4.19
T2 / TE2	02		1.63	2.18	2.89	3.81	4.92	5.95
T2 / TE2	03		2.76	3.70	4.93	6.51	8.46	10.30
T2 / TE2	04		4.23	5.53	7.32	9.68	12.50	15.30
T2 / TE2	05		5.52	7.24	9.64	13.00	17.30	21.70
T2 / TE2	06		6.42	8.43	11.20	15.10	20.30	25.80

Subcooling correction factor 'fsub'

Subcooling [K]	2	4	10	15	20	25	30	35	40	45	50
Correction factor	0.98	1.00	1.05	1.10	1.14	1.19	1.23	1.28	1.32	1.36	1.41

Distributer correction factor 'fp'*

Pressure drop [bar]	Evaporating temp. [°C]												
	-40	-35	-30	-25	-20	-15	-10	-5	0	5	10	15	
0	1	1	1	1	1	1	1	1	1	1	1	1	
1	0.96	0.95	0.95	0.95	0.95	0.95	0.94	0.94	0.93	0.92	0.91	0.89	
1.5	0.93	0.93	0.93	0.93	0.92	0.92	0.91	0.91	0.90	0.88	0.86	0.82	
2	0.91	0.91	0.90	0.90	0.90	0.89	0.88	0.87	0.86	0.84	0.81	0.76	

*calculated at 32 °C condensing temperature

Capacity

Capacity in kW, range B -60 °C to -25 °C. Opening superheat sh= 6 K

R22

Valve type	Orifice no.	Cond. temp. [°C]	Evaporating [°C]			
			-60	-50	-40	-30
			Capacity [kW]			
T2 / TE2	0X	25	0.54	0.67	0.78	0.84
T2 / TE2	00		0.55	0.77	1.03	1.28
T2 / TE2	01		0.72	1.06	1.47	1.95
T2 / TE2	02		0.80	1.17	1.66	2.26
T2 / TE2	03		1.32	1.94	2.76	3.77
T2 / TE2	04		1.87	2.76	3.95	5.45
T2 / TE2	05		2.45	3.60	5.15	7.14
T2 / TE2	06		2.91	4.26	6.10	8.50

Valve type	Orifice no.	Cond. temp. [°C]	Evaporating [°C]			
			-60	-50	-40	-30
			Capacity [kW]			
T2 / TE2	0X	35	0.56	0.69	0.80	0.88
T2 / TE2	00		0.56	0.79	1.06	1.34
T2 / TE2	01		0.74	1.08	1.52	2.04
T2 / TE2	02		0.82	1.20	1.72	2.36
T2 / TE2	03		1.35	1.99	2.85	3.93
T2 / TE2	04		1.90	2.81	4.04	5.63
T2 / TE2	05		2.50	3.66	5.26	7.36
T2 / TE2	06		2.96	4.33	6.21	8.71

Valve type	Orifice no.	Cond. temp. [°C]	Evaporating [°C]			
			-60	-50	-40	-30
			Capacity [kW]			
T2 / TE2	0X	45	0.56	0.70	0.82	0.91
T2 / TE2	00		0.57	0.80	1.08	1.37
T2 / TE2	01		0.75	1.10	1.55	2.09
T2 / TE2	02		0.82	1.22	1.74	2.41
T2 / TE2	03		1.36	2.01	2.88	4.00
T2 / TE2	04		1.91	2.82	4.06	5.70
T2 / TE2	05		2.52	3.68	5.29	7.42
T2 / TE2	06		2.98	4.35	6.23	8.75

Valve type	Orifice no.	Cond. temp. [°C]	Evaporating [°C]			
			-60	-50	-40	-30
			Capacity [kW]			
T2 / TE2	0X	55	0.56	0.70	0.82	0.91
T2 / TE2	00		0.57	0.80	1.08	1.38
T2 / TE2	01		0.75	1.10	1.55	2.10
T2 / TE2	02		0.82	1.21	1.74	2.41
T2 / TE2	03		1.36	2.00	2.87	4.01
T2 / TE2	04		1.89	2.79	4.03	5.66
T2 / TE2	05		2.52	3.67	5.25	7.37
T2 / TE2	06		2.98	4.32	6.17	8.66

Subcooling correction factor 'fsub'

Subcooling [K]	2	4	10	15	20	25	30	35	40	45	50
Correction factor	0.98	1.00	1.07	1.12	1.18	1.23	1.28	1.34	1.39	1.45	1.50

Distributer correction factor 'fp'*

Pressure drop [bar]	Evaporating temp. [°C]												
	-40	-35	-30	-25	-20	-15	-10	-5	0	5	10	15	
"Pressure drop [bar]"	0	1	1	1	1	1	1	1	1	1	1	1	1
	1	0.96	0.96	0.96	0.96	0.96	0.96	0.95	0.95	0.95	0.94	0.93	0.92
	1.5	0.94	0.94	0.94	0.94	0.94	0.93	0.93	0.93	0.92	0.91	0.90	0.88
	2	0.92	0.92	0.92	0.92	0.91	0.91	0.91	0.90	0.89	0.88	0.86	0.84

*calculated at 32 °C condensing temperature

Capacity

Capacity in kW, range N -40 °C to +10 °C. Opening superheat sh= 6 K

R407C

Valve type	Orifice no.	Cond. temp. [°C]	Evaporating [°C]					
			-40	-30	-20	-10	0	10
			Capacity [kW]					
T2 / TE2	0X	25	0.76	0.83	0.88	0.90	0.88	0.81
T2 / TE2	00		0.99	1.21	1.42	1.60	1.69	1.63
T2 / TE2	01		1.41	1.80	2.27	2.77	3.19	3.31
T2 / TE2	02		1.59	2.06	2.67	3.40	4.18	4.64
T2 / TE2	03		2.65	3.44	4.46	5.73	7.07	7.85
T2 / TE2	04		3.86	4.98	6.44	8.35	10.60	12.50
T2 / TE2	05		5.04	6.52	8.46	11.00	14.00	16.30
T2 / TE2	06		5.94	7.71	10.10	13.20	16.80	19.40

Valve type	Orifice no.	Cond. temp. [°C]	Evaporating [°C]					
			-40	-30	-20	-10	0	10
			Capacity [kW]					
T2 / TE2	0X	35	0.76	0.84	0.90	0.94	0.95	0.92
T2 / TE2	00		0.99	1.22	1.45	1.67	1.81	1.85
T2 / TE2	01		1.40	1.81	2.32	2.88	3.43	3.76
T2 / TE2	02		1.59	2.08	2.72	3.54	4.48	5.28
T2 / TE2	03		2.66	3.48	4.57	5.98	7.62	8.98
T2 / TE2	04		3.93	5.10	6.65	8.74	11.40	14.20
T2 / TE2	05		5.13	6.66	8.73	11.50	15.10	18.60
T2 / TE2	06		6.01	7.85	10.40	13.80	18.10	22.20

Valve type	Orifice no.	Cond. temp. [°C]	Evaporating [°C]					
			-40	-30	-20	-10	0	10
			Capacity [kW]					
T2 / TE2	0X	45	0.73	0.82	0.89	0.94	0.97	0.97
T2 / TE2	00		0.95	1.19	1.43	1.67	1.85	1.94
T2 / TE2	01		1.36	1.77	2.28	2.88	3.50	3.97
T2 / TE2	02		1.55	2.04	2.69	3.54	4.58	5.58
T2 / TE2	03		2.60	3.42	4.53	6.01	7.82	9.52
T2 / TE2	04		3.89	5.07	6.66	8.83	11.70	15.00
T2 / TE2	05		5.06	6.62	8.73	11.70	15.60	19.80
T2 / TE2	06		5.90	7.76	10.30	13.90	18.70	23.60

Valve type	Orifice no.	Cond. temp. [°C]	Evaporating [°C]					
			-40	-30	-20	-10	0	10
			Capacity [kW]					
T2 / TE2	0X	55	0.68	0.77	0.85	0.91	0.95	0.96
T2 / TE2	00		0.89	1.12	1.37	1.61	1.81	1.93
T2 / TE2	01		1.27	1.67	2.18	2.78	3.43	3.96
T2 / TE2	02		1.46	1.93	2.57	3.42	4.49	5.58
T2 / TE2	03		2.46	3.27	4.36	5.84	7.71	9.60
T2 / TE2	04		3.74	4.90	6.48	8.65	11.60	15.10
T2 / TE2	05		4.85	6.39	8.49	11.40	15.40	20.00
T2 / TE2	06		5.61	7.45	9.99	13.60	18.50	24.00

Subcooling correction factor 'fsub'

Subcooling [K]	2	4	10	15	20	25	30	35	40	45	50
Correction factor	0.98	1.00	1.07	1.12	1.18	1.23	1.28	1.34	1.39	1.45	1.50

Distributer correction factor 'fp'*

Pressure drop [bar]	Evaporating temp. [°C]												
	-40	-35	-30	-25	-20	-15	-10	-5	0	5	10	15	
0	1	1	1	1	1	1	1	1	1	1	1	1	
1	0.96	0.96	0.96	0.96	0.96	0.96	0.95	0.95	0.95	0.94	0.93	0.92	
1.5	0.94	0.94	0.94	0.94	0.94	0.93	0.93	0.93	0.92	0.91	0.90	0.88	
2	0.92	0.92	0.92	0.92	0.91	0.91	0.91	0.90	0.89	0.88	0.86	0.84	

*calculated at 32 °C condensing temperature

Capacity

Capacity in kW, range N -40 °C to +10 °C. Opening superheat sh= 6 K

R134a

Valve type	Orifice no.	Cond. temp. [°C]	Evaporating [°C]					
			-40	-30	-20	-10	0	10
			Capacity [kW]					
T2 / TE2	0X	25	0.48	0.54	0.59	0.62	0.61	0.54
T2 / TE2	00		0.52	0.67	0.82	0.95	1.03	0.98
T2 / TE2	01		0.70	0.92	1.19	1.48	1.72	1.77
T2 / TE2	02		0.78	1.03	1.35	1.73	2.08	2.24
T2 / TE2	03		1.31	1.72	2.27	2.89	3.49	3.76
T2 / TE2	04		1.89	2.49	3.28	4.21	5.15	5.69
T2 / TE2	05		2.50	3.28	4.33	5.57	6.80	7.48
T2 / TE2	06		2.98	3.93	5.20	6.69	8.16	8.96

Valve type	Orifice no.	Cond. temp. [°C]	Evaporating [°C]					
			-40	-30	-20	-10	0	10
			Capacity [kW]					
T2 / TE2	0X	35	0.49	0.57	0.63	0.67	0.69	0.66
T2 / TE2	00		0.54	0.69	0.86	1.03	1.17	1.22
T2 / TE2	01		0.72	0.96	1.25	1.60	1.95	2.20
T2 / TE2	02		0.81	1.07	1.43	1.87	2.36	2.79
T2 / TE2	03		1.36	1.80	2.40	3.14	3.96	4.69
T2 / TE2	04		2.02	2.64	3.51	4.60	5.85	7.07
T2 / TE2	05		2.66	3.48	4.62	6.06	7.72	9.31
T2 / TE2	06		3.15	4.14	5.51	7.24	9.24	11.10

Valve type	Orifice no.	Cond. temp. [°C]	Evaporating [°C]					
			-40	-30	-20	-10	0	10
			Capacity [kW]					
T2 / TE2	0X	45	0.49	0.57	0.64	0.69	0.73	0.74
T2 / TE2	00		0.54	0.70	0.88	1.07	1.25	1.36
T2 / TE2	01		0.73	0.97	1.28	1.66	2.08	2.46
T2 / TE2	02		0.82	1.09	1.46	1.93	2.51	3.11
T2 / TE2	03		1.38	1.83	2.45	3.25	4.22	5.24
T2 / TE2	04		2.10	2.73	3.63	4.80	6.24	7.89
T2 / TE2	05		2.76	3.59	4.76	6.31	8.23	10.40
T2 / TE2	06		3.25	4.24	5.64	7.51	9.82	12.40

Valve type	Orifice no.	Cond. temp. [°C]	Evaporating [°C]					
			-40	-30	-20	-10	0	10
			Capacity [kW]					
T2 / TE2	0X	55	0.47	0.56	0.63	0.69	0.74	0.76
T2 / TE2	00		0.53	0.69	0.87	1.07	1.27	1.43
T2 / TE2	01		0.72	0.95	1.26	1.65	2.11	2.57
T2 / TE2	02		0.81	1.08	1.45	1.94	2.55	3.24
T2 / TE2	03		1.38	1.82	2.44	3.27	4.30	5.50
T2 / TE2	04		2.14	2.77	3.66	4.85	6.38	8.25
T2 / TE2	05		2.81	3.63	4.80	6.37	8.40	10.90
T2 / TE2	06		3.30	4.26	5.65	7.54	10.00	13.00

Subcooling correction factor 'fsub'

Subcooling [K]	2	4	10	15	20	25	30	35	40	45	50
Correction factor	0.98	1.00	1.07	1.12	1.18	1.23	1.29	1.34	1.40	1.45	1.50

Distributer correction factor 'fp' *

Pressure drop [bar]	Evaporating temp. [°C]												
	-40	-35	-30	-25	-20	-15	-10	-5	0	5	10	15	
0	1	1	1	1	1	1	1	1	1	1	1	1	
1	0.93	0.93	0.93	0.93	0.92	0.92	0.92	0.91	0.90	0.89	0.87	0.83	
1.5	0.90	0.89	0.89	0.89	0.88	0.88	0.87	0.86	0.84	0.82	0.79	0.74	
2	0.86	0.86	0.85	0.85	0.84	0.83	0.82	0.81	0.79	0.76	0.71	0.62	

*calculated at 32 °C condensing temperature

Capacity

Capacity in kW, range N -40 °C to +10 °C. Opening superheat sh= 6 K

R404A

Valve type	Orifice no.	Cond. temp. [°C]	Evaporating [°C]					
			-40	-30	-20	-10	0	10
			Capacity [kW]					
T2 / TE2	0X	25	0.55	0.61	0.64	0.65	0.62	0.54
T2 / TE2	00		0.72	0.92	1.09	1.21	1.22	1.08
T2 / TE2	01		1.00	1.38	1.81	2.20	2.40	2.25
T2 / TE2	02		1.12	1.58	2.17	2.79	3.25	3.22
T2 / TE2	03		1.86	2.65	3.65	4.72	5.49	5.42
T2 / TE2	04		2.68	3.83	5.36	7.12	8.53	8.69
T2 / TE2	05		3.51	5.04	7.06	9.38	11.20	11.30
T2 / TE2	06		4.15	5.99	8.43	11.20	13.40	13.30

Valve type	Orifice no.	Cond. temp. [°C]	Evaporating [°C]					
			-40	-30	-20	-10	0	10
			Capacity [kW]					
T2 / TE2	0X	35	0.52	0.59	0.64	0.67	0.68	0.64
T2 / TE2	00		0.67	0.88	1.08	1.25	1.34	1.29
T2 / TE2	01		0.95	1.33	1.79	2.28	2.64	2.70
T2 / TE2	02		1.07	1.53	2.15	2.90	3.59	3.89
T2 / TE2	03		1.78	2.57	3.64	4.93	6.11	6.57
T2 / TE2	04		2.60	3.75	5.37	7.45	9.53	10.60
T2 / TE2	05		3.40	4.93	7.07	9.82	12.50	13.70
T2 / TE2	06		4.00	5.83	8.40	11.70	14.90	16.30

Valve type	Orifice no.	Cond. temp. [°C]	Evaporating [°C]					
			-40	-30	-20	-10	0	10
			Capacity [kW]					
T2 / TE2	0X	45	0.46	0.54	0.60	0.65	0.68	0.67
T2 / TE2	00		0.61	0.81	1.01	1.20	1.34	1.38
T2 / TE2	01		0.86	1.22	1.68	2.19	2.66	2.87
T2 / TE2	02		0.97	1.41	2.02	2.81	3.64	4.16
T2 / TE2	03		1.63	2.38	3.43	4.80	6.23	7.06
T2 / TE2	04		2.43	3.50	5.08	7.26	9.74	11.40
T2 / TE2	05		3.17	4.60	6.69	9.58	12.90	14.90
T2 / TE2	06		3.71	5.41	7.92	11.40	15.40	17.70

Valve type	Orifice no.	Cond. temp. [°C]	Evaporating [°C]					
			-40	-30	-20	-10	0	10
			Capacity [kW]					
T2 / TE2	0X	55	0.39	0.47	0.54	0.59	0.62	0.64
T2 / TE2	00		0.52	0.70	0.89	1.07	1.23	1.30
T2 / TE2	01		0.74	1.06	1.47	1.96	2.44	2.73
T2 / TE2	02		0.85	1.23	1.78	2.52	3.35	3.96
T2 / TE2	03		1.43	2.09	3.03	4.32	5.78	6.76
T2 / TE2	04		2.17	3.10	4.50	6.51	8.98	10.90
T2 / TE2	05		2.83	4.07	5.92	8.61	11.90	14.40
T2 / TE2	06		3.29	4.77	6.99	10.30	14.30	17.20

Subcooling correction factor 'fsub'

Subcooling [K]	2	4	10	15	20	25	30	35	40	45	50
Correction factor	0.97	1.00	1.09	1.16	1.23	1.30	1.38	1.45	1.52	1.59	1.65

Distributer correction factor 'fp'*

Pressure drop [bar]	Evaporating temp. [°C]												
	-40	-35	-30	-25	-20	-15	-10	-5	0	5	10	15	
0	1	1	1	1	1	1	1	1	1	1	1	1	
1	0.96	0.96	0.96	0.96	0.96	0.96	0.95	0.95	0.94	0.94	0.92	0.91	
1.5	0.94	0.94	0.94	0.94	0.94	0.93	0.93	0.92	0.91	0.90	0.88	0.86	
2	0.92	0.92	0.92	0.92	0.91	0.91	0.90	0.89	0.88	0.87	0.84	0.80	

*calculated at 32 °C condensing temperature

Capacity

Capacity in kW, range B, -60 °C to -25 °C, opening superheat sh= 6 K

R404A

Valve type	Orifice no.	Cond. temp. [°C]	Evaporating [°C]			
			-60	-50	-40	-30
			Capacity [kW]			
T2 / TE2	0X	25	0.44	0.51	0.58	0.63
T2 / TE2	00		0.50	0.65	0.83	1.02
T2 / TE2	01		0.68	0.90	1.22	1.62
T2 / TE2	02		0.75	1.00	1.39	1.91
T2 / TE2	03		1.22	1.64	2.30	3.22
T2 / TE2	04		1.69	2.31	3.23	4.46
T2 / TE2	05		2.20	3.02	4.22	5.82
T2 / TE2	06		2.60	3.55	4.98	6.92

Valve type	Orifice no.	Cond. temp. [°C]	Evaporating [°C]			
			-60	-50	-40	-30
			Capacity [kW]			
T2 / TE2	0X	35	0.41	0.49	0.56	0.62
T2 / TE2	00		0.47	0.61	0.80	1.00
T2 / TE2	01		0.64	0.86	1.18	1.59
T2 / TE2	02		0.70	0.96	1.34	1.88
T2 / TE2	03		1.16	1.58	2.24	3.18
T2 / TE2	04		1.72	2.31	3.22	4.47
T2 / TE2	05		2.23	3.01	4.19	5.83
T2 / TE2	06		2.63	3.51	4.90	6.87

Valve type	Orifice no.	Cond. temp. [°C]	Evaporating [°C]			
			-60	-50	-40	-30
			Capacity [kW]			
T2 / TE2	0X	45	0.36	0.44	0.52	0.58
T2 / TE2	00		0.41	0.55	0.73	0.93
T2 / TE2	01		0.56	0.77	1.08	1.48
T2 / TE2	02		0.63	0.86	1.23	1.76
T2 / TE2	03		1.04	1.44	2.07	2.99
T2 / TE2	04		1.68	2.20	3.04	4.23
T2 / TE2	05		2.16	2.84	3.94	5.52
T2 / TE2	06		2.57	3.30	4.57	6.46

Valve type	Orifice no.	Cond. temp. [°C]	Evaporating [°C]			
			-60	-50	-40	-30
			Capacity [kW]			
T2 / TE2	0X	55	0.29	0.36	0.44	0.50
T2 / TE2	00		0.33	0.46	0.62	0.81
T2 / TE2	01		0.46	0.64	0.92	1.29
T2 / TE2	02		0.51	0.73	1.06	1.54
T2 / TE2	03		0.86	1.22	1.80	2.65
T2 / TE2	04		1.56	1.96	2.67	3.73
T2 / TE2	05		1.98	2.50	3.44	4.85
T2 / TE2	06		2.39	2.93	3.97	5.63

Subcooling correction factor 'fsub'

Subcooling [K]	2	4	10	15	20	25	30	35	40	45	50
Correction factor	0.97	1.00	1.10	1.19	1.27	1.35	1.43	1.52	1.60	1.68	1.76

Distributer correction factor 'fp'*

Pressure drop [bar]	Evaporating temp. [°C]								
	-60	-55	-50	-45	-40	-35	-30	-25	
0	1	1	1	1	1	1	1	1	
1	0.97	0.96	0.96	0.96	0.96	0.96	0.96	0.96	
1.5	0.95	0.95	0.95	0.94	0.94	0.94	0.94	0.94	
2	0.93	0.93	0.93	0.93	0.92	0.92	0.92	0.92	

*calculated at 32 °C condensing temperature

Capacity

Capacity in kW, range N -40 °C to +10 °C. Opening superheat sh= 6 K

R407F

Valve type	Orifice no.	Cond. temp. [°C]	Evaporating [°C]					
			-40	-30	-20	-10	0	10
			Capacity [kW]					
T2 / TE2	0X	25	0.84	0.92	0.96	0.98	0.95	0.86
T2 / TE2	00		1.1	1.4	1.6	1.8	1.8	1.7
T2 / TE2	01		1.6	2.0	2.6	3.1	3.6	3.6
T2 / TE2	02		1.8	2.3	3.0	3.9	4.8	5.1
T2 / TE2	03		2.9	3.9	5.1	6.6	8.1	8.7
T2 / TE2	04		4.3	5.6	7.4	9.6	12.2	14.0
T2 / TE2	05		5.6	7.4	9.7	12.7	16.1	18.1
T2 / TE2	06		6.6	8.7	11.6	15.2	19.3	21.5

Valve type	Orifice no.	Cond. temp. [°C]	Evaporating [°C]					
			-40	-30	-20	-10	0	10
			Capacity [kW]					
T2 / TE2	0X	35	0.85	0.93	0.99	1.0	1.0	0.98
T2 / TE2	00		1.1	1.4	1.6	1.9	2.0	2.0
T2 / TE2	01		1.6	2.1	2.7	3.3	3.9	4.1
T2 / TE2	02		1.8	2.4	3.1	4.1	5.2	5.9
T2 / TE2	03		3.0	4.0	5.3	7.0	8.8	10.0
T2 / TE2	04		4.4	5.8	7.7	10.2	13.3	16.0
T2 / TE2	05		5.8	7.6	10.1	13.5	17.5	20.9
T2 / TE2	06		6.7	9.0	12.0	16.1	21.0	24.8

Valve type	Orifice no.	Cond. temp. [°C]	Evaporating [°C]					
			-40	-30	-20	-10	0	10
			Capacity [kW]					
T2 / TE2	0X	45	0.83	0.92	0.99	1.0	1.1	1.0
T2 / TE2	00		1.1	1.4	1.6	1.9	2.0	2.1
T2 / TE2	01		1.5	2.0	2.6	3.3	4.0	4.4
T2 / TE2	02		1.8	2.3	3.1	4.1	5.3	6.3
T2 / TE2	03		3.0	4.0	5.3	7.1	9.1	10.7
T2 / TE2	04		4.4	5.9	7.8	10.4	13.8	17.1
T2 / TE2	05		5.8	7.6	10.2	13.8	18.3	22.4
T2 / TE2	06		6.7	8.9	12.1	16.4	21.9	26.6

Valve type	Orifice no.	Cond. temp. [°C]	Evaporating [°C]					
			-40	-30	-20	-10	0	10
			Capacity [kW]					
T2 / TE2	0X	55	0.79	0.89	0.96	1.0	1.0	1.0
T2 / TE2	00		1.0	1.3	1.6	1.8	2.0	2.1
T2 / TE2	01		1.5	2.0	2.6	3.3	3.9	4.4
T2 / TE2	02		1.7	2.3	3.0	4.1	5.3	6.4
T2 / TE2	03		2.9	3.8	5.2	7.0	9.1	10.9
T2 / TE2	04		4.3	5.7	7.7	10.3	13.8	17.4
T2 / TE2	05		5.6	7.5	10.1	13.7	18.4	22.9
T2 / TE2	06		6.5	8.7	11.9	16.3	22.1	27.4

Subcooling correction factor 'fsub'

Subcooling [K]	1	4	10	15	20	25	30	35	40	45	50
Correction factor	0.96	1.00	1.07	1.14	1.20	1.26	1.33	1.40	1.47	1.54	1.65

Distributer correction factor 'fp'*

Pressure drop [bar]		Evaporating temp. [°C]											
		-40	-35	-30	-25	-20	-15	-10	-5	0	5	10	15
"Pressure drop [bar]"	0	1	1	1	1	1	1	1	1	1	1	1	1
	1	1.00	0.93	0.91	0.88	0.87	0.82	0.79	0.76	0.73	0.69	0.65	0.91
	1.5	1.04	0.91	0.88	0.84	0.82	0.77	0.74	0.69	0.64	0.60	0.57	0.86
	2	1.07	0.93	0.85	0.81	0.77	0.72	0.67	0.63	0.58	0.54	0.50	0.80

*calculated at 32 °C condensing temperature

Capacity

Capacity in kW, range N -40 °C to +10 °C. Opening superheat sh= 6 K

R407A

Valve type	Orifice no.	Cond. temp. [°C]	Evaporating [°C]					
			-40	-30	-20	-10	0	10
			Capacity [kW]					
T2 / TE2	0X	25	0.74	0.81	0.86	0.87	0.85	0.77
T2 / TE2	00		0.97	1.2	1.4	1.6	1.7	1.6
T2 / TE2	01		1.4	1.8	2.3	2.8	3.2	3.2
T2 / TE2	02		1.6	2.1	2.7	3.5	4.3	4.6
T2 / TE2	03		2.6	3.4	4.6	5.9	7.3	7.8
T2 / TE2	04		3.8	5.0	6.6	8.6	11.0	12.6
T2 / TE2	05		5.0	6.5	8.6	11.4	14.5	16.4
T2 / TE2	06		5.8	7.7	10.3	13.6	17.3	19.4

Valve type	Orifice no.	Cond. temp. [°C]	Evaporating [°C]					
			-40	-30	-20	-10	0	10
			Capacity [kW]					
T2 / TE2	0X	35	0.74	0.82	0.88	0.91	0.91	0.88
T2 / TE2	00		0.97	1.2	1.4	1.7	1.8	1.8
T2 / TE2	01		1.4	1.8	2.3	2.9	3.4	3.7
T2 / TE2	02		1.6	2.1	2.8	3.6	4.6	5.3
T2 / TE2	03		2.6	3.5	4.7	6.2	7.8	9.0
T2 / TE2	04		3.9	5.1	6.8	9.0	11.9	14.4
T2 / TE2	05		5.0	6.7	8.9	12.0	15.7	18.7
T2 / TE2	06		5.9	7.9	10.6	14.3	18.8	22.2

Valve type	Orifice no.	Cond. temp. [°C]	Evaporating [°C]					
			-40	-30	-20	-10	0	10
			Capacity [kW]					
T2 / TE2	0X	45	0.72	0.80	0.87	0.91	0.93	0.92
T2 / TE2	00		0.94	1.2	1.4	1.7	1.8	1.9
T2 / TE2	01		1.3	1.8	2.3	2.9	3.5	3.9
T2 / TE2	02		1.5	2.0	2.7	3.7	4.7	5.6
T2 / TE2	03		2.6	3.4	4.6	6.2	8.1	9.5
T2 / TE2	04		3.8	5.1	6.8	9.2	12.2	15.2
T2 / TE2	05		5.0	6.6	8.9	12.1	16.2	19.9
T2 / TE2	06		5.8	7.8	10.6	14.5	19.4	23.7

Valve type	Orifice no.	Cond. temp. [°C]	Evaporating [°C]					
			-40	-30	-20	-10	0	10
			Capacity [kW]					
T2 / TE2	0X	55	0.67	0.76	0.83	0.88	0.91	0.92
T2 / TE2	00		0.88	1.1	1.4	1.6	1.8	1.9
T2 / TE2	01		1.3	1.7	2.2	2.8	3.5	3.9
T2 / TE2	02		1.4	1.9	2.6	3.5	4.6	5.6
T2 / TE2	03		2.4	3.3	4.5	6.1	8.0	9.6
T2 / TE2	04		3.7	4.9	6.6	9.0	12.1	15.4
T2 / TE2	05		4.8	6.4	8.7	11.9	16.1	20.3
T2 / TE2	06		5.5	7.5	10.3	14.2	19.4	24.2

Subcooling correction factor 'fsub'

Subcooling [K]	1	4	10	15	20	25	30	35	40	45	50
Correction factor	0.96	1.00	1.08	1.14	1.21	1.28	1.35	1.42	1.50	1.57	1.65

Distributer correction factor 'fp'*

Pressure drop [bar]	Evaporating temp. [°C]												
	-40	-35	-30	-25	-20	-15	-10	-5	0	5	10	15	
0	1	1	1	1	1	1	1	1	1	1	1	1	
1	0.97	0.93	0.92	0.89	0.86	0.83	0.80	0.78	0.74	0.72	0.67	0.91	
1.5	1.01	0.92	0.88	0.85	0.81	0.78	0.73	0.71	0.67	0.63	0.59	0.86	
2	1.01	0.90	0.86	0.82	0.77	0.74	0.69	0.63	0.59	0.56	0.52	0.80	

*calculated at 32 °C condensing temperature

Dimensions and weights

T 2 and TE 2

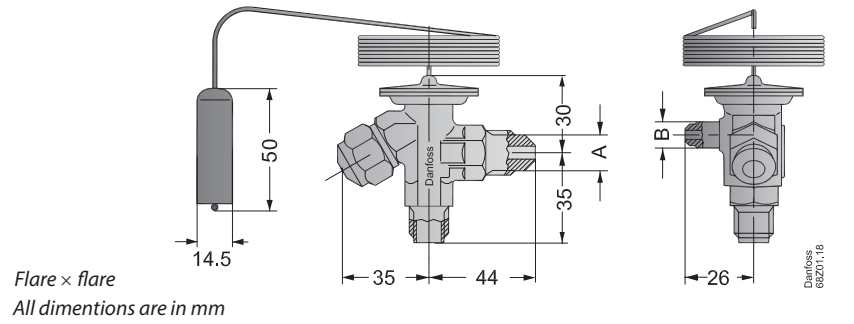

Flare x flare
All dimensions are in mm

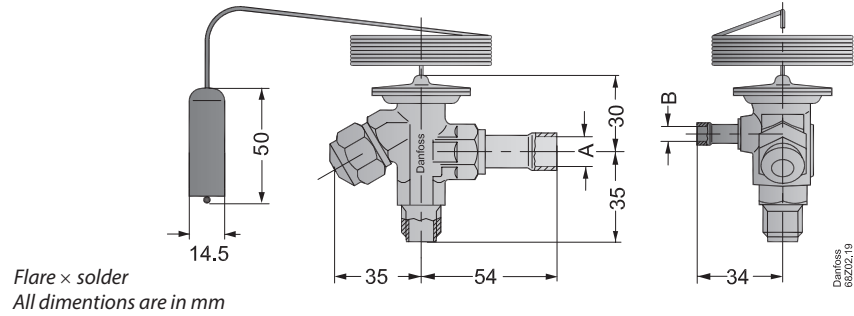

Flare x solder
All dimensions are in mm

	Outlet A	Equalization B	Weight [kg / lb]
Flare x flare	1/2" flare	1/4" flare	0.3 / 0.7
Flare x solder	1/2" solder 12 mm solder	1/4" solder 6 mm solder	0.3 / 0.7

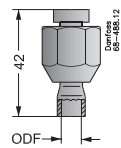

Solder adaptor

Solder ODF		Weight [kg / lb]
in.	mm	
1/4	6	0.05 / 0.11
3/8	10	0.05 / 0.11